

# MLX90287

## 12V Low Noise Single Coil Motor Driver with PWM

### Features and Benefits

- Full integrated fan driver including hall position sensor
- High magnetic sensitivity
- High output current
- PWM speed control with minimum speed setting
- Accepts wide input frequency range, and converts to fixed 30kHz output frequency
- Built-in pull up resistor on PWM input ensures fail safe operation in case of broken wire
- Protections: Reverse voltage, Brown out, Thermal Protection, LRP, high ESD rating
- Automatic Gain Control (AGC) based soft switching for low noise operation over wide speed range
- Intelligent Soft Start suppresses high peak currents during start up
- Qualified according to AEC-Q100.

### Applications

- Speed controlled single coil fans and pumps with 12V supply
- Automotive and non-automotive applications

### Ordering Information

Product Code	Temperature Code	Package Code	Option code	Packing form code
• MLX90287	L	ZC	AAA-000	RX
• MLX90287	L	DC	AAA-000	RE
• MLX90287	K	ZC	AAA-000	RX
• MLX90287	L	LD <sup>(1)</sup>	AAA- 000	RE
• MLX90287	L	ZC	ABA-000 <sup>(1)</sup>	RX

#### Legend:

Temperature Code:

- K: for Temperature Range - 40°C to 125°C
- L: for Temperature Range - 40°C to 150°C

Package Code:           **xx**

- ZC: SOIC8 with straight leads
- DC: SOIC8 with bent leads (gull wing)
- LD: for DFN10 3\*3<sup>(1)</sup>

Option Code:           **xxx-yyy:**

xxx: Die version

- AAx: FG
- ABx: RD<sup>(1)</sup>

Packing Form Code:

- RE for Reel (face-up/live bug)
- RX for Reel (face down/dead bug)
- TU for Tube

---

<sup>1</sup> on high volume demand

---

### Table of Contents

Features and Benefits .....	1
Applications.....	1
Ordering Information.....	1
Table of Contents.....	2
1 Glossary of Terms.....	3
2 Absolute Maximum Ratings.....	3
3 General Electrical Specifications .....	4
4 Output Behaviour versus Magnetic Pole .....	5
5 Pin Definitions and Descriptions .....	5
6 Block Diagram .....	6
7 General Description .....	6
8 Performance Graphs .....	8
8.1 $I_{DD}$ vs. $T_J$ .....	8
8.2 $I_{DD}$ vs. $V_{DD}$ .....	8
8.3 $V_{OL}$ vs. $T_J$ .....	8
8.4 $V_{OL}$ vs. $V_{DD}$ .....	8
8.5 $I_{OFF}$ vs. $T_J$ .....	8
8.6 Power Derating vs. $T_J$ .....	8
9 Application Information .....	9
4-Wire PWM Cooling Fan .....	9
(no minimal speed setting).....	9
4-Wire PWM Cooling Fan .....	9
(with minimal speed setting).....	9
Temperature Controlled Cooling Fan .....	9
2-Speed Cooling Fan.....	9
9.1 Application Comments .....	9
10 Standard information regarding manufacturability of Melexis products with different soldering processes.....	10
11 ESD Precautions .....	10
12 Package Information .....	11
12.1 DC Package (SOIC8 NB).....	11
12.2 ZC Package (SOIC8 NB with straight leads).....	12
12.3 DFN10 3*3mm.....	13
13 Disclaimer .....	14

---

# MLX90287

## 12V Low Noise Single Coil Motor Driver with PWM

### 1 Glossary of Terms

MilliTesla (mT), Gauss	Units of magnetic flux density: 1mT = 10 Gauss
RoHS	Restriction of Hazardous Substances
DC	Small Outline Integrated Circuit (SOIC package) – also referred with the Melexis package code “DC”
PWM	Pulse Width Modulation
ESD	Electro-Static Discharge

### 2 Absolute Maximum Ratings

Parameter	Symbol	Value	Units
Supply Voltage <sup>(1, 2)</sup>	V <sub>DD</sub>	+18	V
Supply Current <sup>(1, 2, 3)</sup>	I <sub>DD</sub>	+20	mA
Reverse Supply Voltage <sup>(1, 2)</sup>	V <sub>DDREV</sub>	-18	V
Reverse Supply Current <sup>(1, 4, 2)</sup>	I <sub>DDREV</sub>	-20	mA
FG Output Voltage <sup>(1, 2)</sup>	V <sub>FG</sub>	+18	V
FG Output current <sup>(1, 2, 3)</sup>	I <sub>FG</sub>	+30	mA
Reverse FG Output Current <sup>(1, 2, 3)</sup>	I <sub>FG</sub>	-50	mA
PWM input voltage <sup>(1, 2)</sup>	V <sub>PWM</sub>	+7	V
Reverse PWM input voltage <sup>(1)</sup>	V <sub>PWM</sub>	-0.3	V
MINSP input voltage <sup>(1, 2)</sup>	V <sub>MINSP</sub>	+3.6	V
Reverse MINSP voltage <sup>(1)</sup>	V <sub>MINSP</sub>	-0.3	V
Reverse current on MINSP or PWM <sup>(1, 2)</sup>	I <sub>MINSP</sub> , I <sub>PWM</sub>	-10	mA
Average Output Current <sup>(1, 2, 3)</sup>	I <sub>OUT</sub>	+500	mA
Peak Output Current <sup>(1, 5)</sup>	I <sub>OUT</sub>	+1000	mA
Operating Temperature Range	T <sub>A</sub>	-40 to +150	°C
Storage Temperature Range	T <sub>S</sub>	-55 to +165	°C
Maximum Junction Temperature <sup>(6)</sup>	T <sub>J</sub>	+165	°C
ESD Sensitivity – HBM <sup>(7)</sup>	-	6000	V
Magnetic Flux Density	B	Unlimited	mT

Exceeding the absolute maximum ratings may cause permanent damage. Exposure to absolute-maximum-rated conditions for extended periods may affect device reliability.

<sup>1</sup> The maximum junction temperature should not be exceeded

<sup>2</sup> For maximum 1 hour

<sup>3</sup> Including current through protection device

<sup>4</sup> Through protection device

<sup>5</sup> For maximum 0.5sec

<sup>6</sup> For 1000 hours.

<sup>7</sup> Human Model according AEC-Q100-002 standard

# MLX90287

## 12V Low Noise Single Coil Motor Driver with PWM

### 3 General Electrical Specifications

DC Operating Parameters  $T_j = -40^{\circ}\text{C}$  to  $150^{\circ}\text{C}$ ,  $V_{DD} = 4.5\text{V}$  to  $16\text{V}$  (unless otherwise specified)

Parameter	Symbol	Test Conditions	Min	Typ <sup>(8)</sup>	Max	Units
Supply Voltage	$V_{DD}$	Operating	4.5	12	16	V
Supply Current	$I_{DD}$			3	6	mA
Reverse Supply Current	$I_{DDREV}$	$V_{DD} = -16\text{V}$			1	mA
PWM Input Low Voltage	$V_{IL}$				0.8	V
PWM Input High Voltage	$V_{IH}$		2.1		5.5	V
PWM Input Frequency	$F_{IN}$		0.1		100	kHz
PWM internal pull-up resistor <sup>(9)</sup>	$R_{IN}$			10		k $\Omega$
Full Bridge On Resistance	$R_{DSON}$	$T_j = 25^{\circ}\text{C}$ , 12V, 350mA		2.5	6.6	$\Omega$
Full Bridge On Resistance	$R_{DSON}$	$T_j = 25^{\circ}\text{C}$ , 4.5V, 150mA		3.8	9.4	$\Omega$
Output PWM frequency	$F_{OUT}$	$10\% < DC_{IN} < 100\%$	26	30		kHz
Output Duty Cycle Range	$DC_{OUT}$	$V_{MINSP} = 0\text{V}$	0		100	%
Output Duty Cycle Range	$DC_{OUT}$	Resistor R1 between MINSP to VREF, $DC_{IN} < 10\%$	10		100	%
Minimal Speed Setting Resistor	$R_{MINSP}$	$DC_{IN} < 10\%$ , $10\% < DC_{OUT} < 100\%$ , $R_{REF} = 68\text{k}$	40		100	k $\Omega$
Output Duty Cycle Mismatch $DC_{OUT} - DC_{IN}$	$DC_{ERR}$	$V_{DD} = 12\text{V}$ , $T_A = 25^{\circ}\text{C}$ , $F_{IN} = 30\text{kHz}$	-2		2	%
Freewheel Period <sup>(10)</sup>	$T_{FW}$			1		ms
Soft Start Initial Overdrive <sup>(11)-/</sup>	$K_{SOFT}$			40		%
Soft Start Rotation Detector	$E_{SOFT}$			4		Edges
Soft Start Duration	$T_{SOFT}$			1.3	2	s
FG Output Saturation Voltage	$V_{OL}$	$B > B_{OP}$ , $I_{OUT} = 5\text{mA}$		0.2	0.5	V
FG Output Current Limit	$I_{CL}$	$B > B_{OP}$	20	23	26	mA
FG Output Leakage Current	$I_{OFF}$	$V_{OUT} = 16\text{V}$ , $V_{DD} = 12\text{V}$ , $B < Brp$		0.1	10	$\mu\text{A}$
Minimum recommended magnetic field	$B_{HALL}$	$B_{OP} =  B_{HALL} $ , $B_{RP} = - B_{HALL} $		$\pm 3$	$\pm 6$	mT
Output Slope Duration	$T_{SLOPE}$	Total Regulation Range	300		4000	us
Slope to Torque Ratio	$SL_{RATIO}$			12.5		%
Reference Output Voltage	$V_{REF}$		2.9	3.1	3.4	V
Reference Output Current Capability	$I_{REF}$				2	mA
Brown-Out Detector Threshold	$V_{BOD}$		3.8	4.1	4.4	V
Brown-Out Detector Reaction Time	$T_{BOD}$			8		ms
Locked Rotor Protection ON time	$T_{ON}$			0.5		s
Locked Rotor Protection OFF time	$T_{OFF}$			3		s
Thermal Protection Threshold	$T_{PROT}$	Junction temperature		170		$^{\circ}\text{C}$
Thermal Protection Release	$T_{REL}$	Junction temperature		155		$^{\circ}\text{C}$
Package Thermal Resistance	$Th_{ja\_ZC}$ $Th_{ja\_DC}$	SOIC8: Single layer PCB, JEDEC standard test boards, still air (LFPM=0) <sup>(12)</sup>		150		$^{\circ}\text{C}/\text{W}$
Package Thermal resistance DFN10	$Th_{ja\_LD}$	DFN10: Single layer PCB, JEDEC standard test boards, still air (LFPM=0) <sup>(5)</sup>		40		K/W

<sup>8</sup> Typical values are defined at  $T_A = +25^{\circ}\text{C}$  and  $V_{DD} = 12\text{V}$ , unless otherwise specified

<sup>9</sup> Internally connected between PWM to VREF

<sup>10</sup> Period when both output NMOST stay ON prior putting the H-bridge in tri-state for LRP, TSD and Brown-out

<sup>11</sup> Initial Output Duty Cycle after power-on

<sup>12</sup> For optimal cooling, maximize the size of the ground plane on the pcb

### 4 Output Behaviour versus Magnetic Pole

DC Operating Parameters  $T_A = -40^{\circ}\text{C}$  to  $150^{\circ}\text{C}$ ,  $V_{DD} = 4.5\text{V}$  to  $16\text{V}$  (unless otherwise specified)

Parameter	Test Conditions	OUT 1	OUT2	FG
South pole	$B > B_{OP}$	Low	High	Low
North pole	$B < B_{RP}$	High	Low	High

Table 1: Output behaviour versus magnetic pole. Magnetic pole facing the top side of the package.

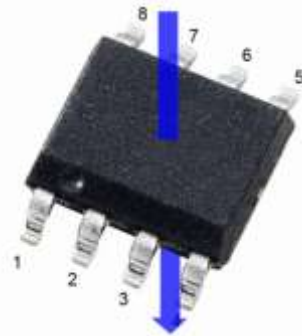

### 5 Pin Definitions and Descriptions

xZC/DC xxx-000	Name	Type	Function
1	PWM	Input	Input for digital speed control
2	FG	Output	Open Drain Tachometer Output
3	OUT1	Output	H-bridge Output1
4	VDD	Power	Supply Voltage pin
5	OUT2	Output	H-bridge Output2
6	GND	Ground	Ground pin
7	MINSPEED	Input	Minimum Speed Setting pin
8	VREF	Power	Reference voltage output pin

Table 2: SOIC8 (ZC/DC) Pin definitions and descriptions

xLD AAA-000	Name	Type	Function
1	PWM	Input	Input for digital speed control
2	FG	Output	Open Drain Tachometer Output
3	OUT1	Output	H-bridge Output1
4	VDD	Power	Supply Voltage pin
5	VDD	Power	Supply Voltage pin
6	GND	Ground	Ground pin
7	OUT2	Output	H-bridge Output2
8	GND	Ground	Ground pin
9	MINSPEED	Input	Minimum Speed Setting pin
10	VREF	Power	Reference voltage output pin

Table 3: DFN10 (LD) Pin definitions and descriptions

# MLX90287

## 12V Low Noise Single Coil Motor Driver with PWM

### 6 Block Diagram

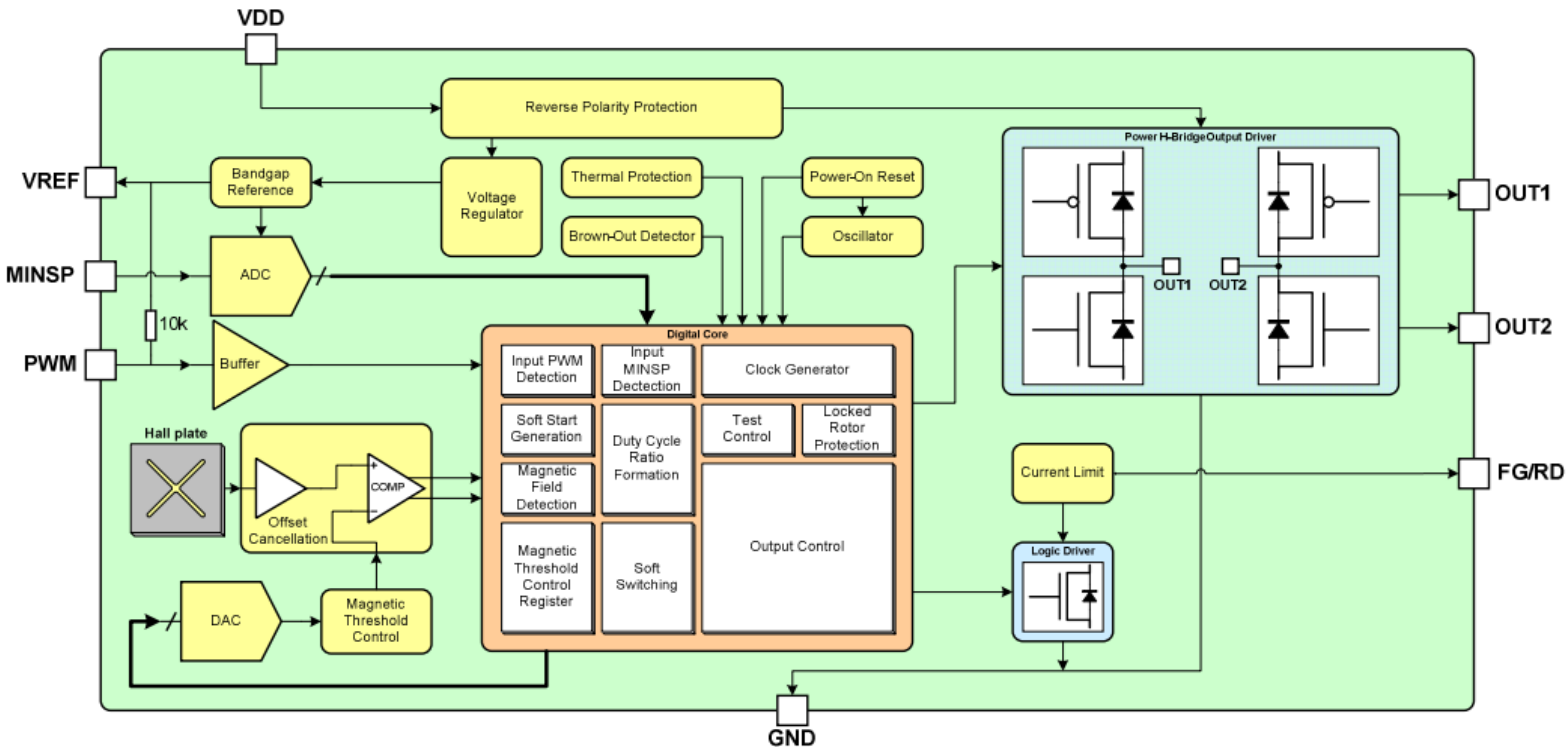

### 7 General Description

The Melexis MLX90287 is a one-chip solution designed in mixed signal CMOS technology for driving single-coil brushless DC motors like PWM cooling fans.

The device integrates a voltage regulator, Hall sensor with advanced offset cancellation system, a power output H-bridge all controlled by a sophisticated digital state machine, all in a single package.

The included voltage regulator operates from 4.5 to 16V, hence covering a wide range of applications. With the built-in reverse voltage protection, no diode on the supply line is required. In case of critical low voltage operation, the Brown-Out Detection will automatically stop the device operation until normal supply voltage in the operational range is applied.

The PWM input allows very wide input frequency range (100Hz to 100kHz) while the output PWM frequency is kept constant above the audible frequency range. The input duty cycle controls the driving of the output duty cycle applied to the motor coil, thus the rotation speed is directly proportional to the input duty cycle with very high accuracy of  $\pm 2\%$  ensuring very good linearity.

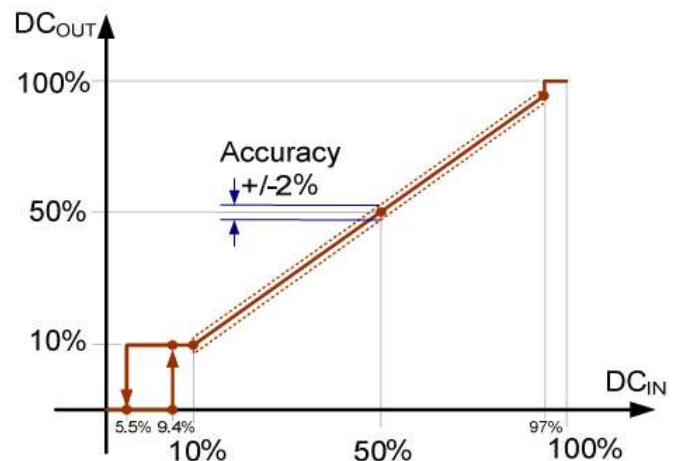

The PWM input features a built-in pull-up resistor of 10kohms tied to the Reference Output Voltage (VREF). Since the interface providing the PWM signal is generally open-collector/drain type, an external resistor is not required. In addition, it provides a fail/safe functionality as it will drive the motor at full speed in case of PWM signal wire-break.

# MLX90287

## 12V Low Noise Single Coil Motor Driver with PWM

The Soft Switching is performed using the output duty cycle rather than analog voltage sweep, leading to less power dissipation. The device automatically adjusts its

slope duration targeting 12.5% from the torque period independent of the rotor magnet strength, producing an optimum balance between high efficiency and low noise performance. The possibility for very long slope duration guarantees extremely quiet operation even at very low rotation speed.

The Intelligent Soft Start prevents very high peak current during start-up. An additional system guarantees proper motor start-up even with low PWM input duty cycle, ensuring enough initial torque to the motor is generated to enable rotation. When motor rotation is detected the output duty cycle is adjusted linearly to the input duty cycle.

The Minimal Speed input allows setting of a minimum required rotation speed of the motor by using 2 inexpensive resistors. This is especially useful for applications where minimum cooling is a requirement to avoid system damage (example: computer CPU, graphics processor, etc ).

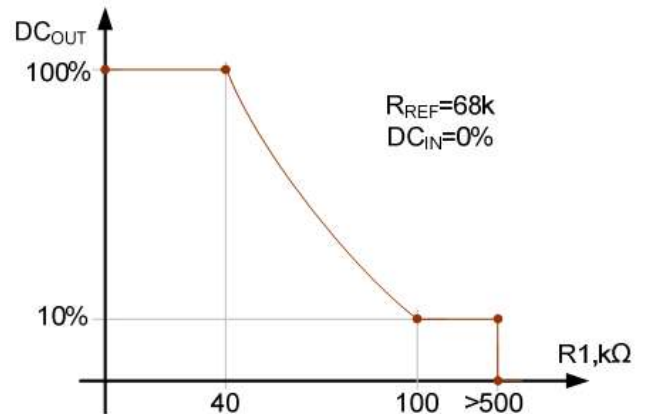

The tachometer open drain output (FG) communicates motor rotation speed to the system and is fully protected against short-circuit.

The device also features Locked Rotor Protection to avoid overheating issues in case of a mechanical blockage of the rotor or bearing failure.

The on-chip Thermal Protection switches off the outputs if the junction temperature increases above an abnormally high threshold. It will automatically recover once the temperature decreases below a safe value.

The MLX90287 is delivered in a Green compliant 8-pin Small-outline Integrated Circuit (SOIC) package for surface-mount process.

# MLX90287

## 12V Low Noise Single Coil Motor Driver with PWM

### 8 Performance Graphs

#### 8.1 $I_{DD}$ vs. $T_J$

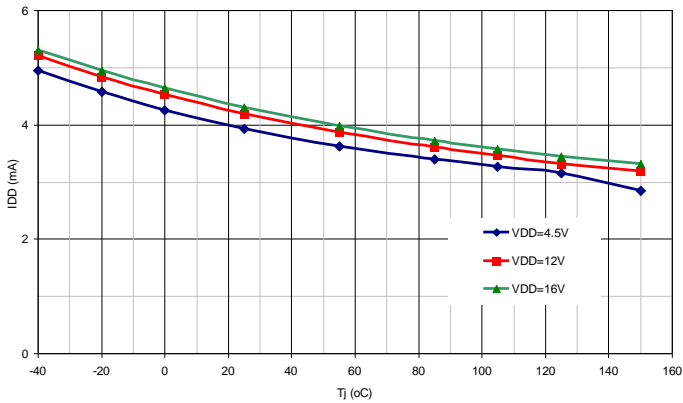

#### 8.2 $I_{DD}$ vs. $V_{DD}$

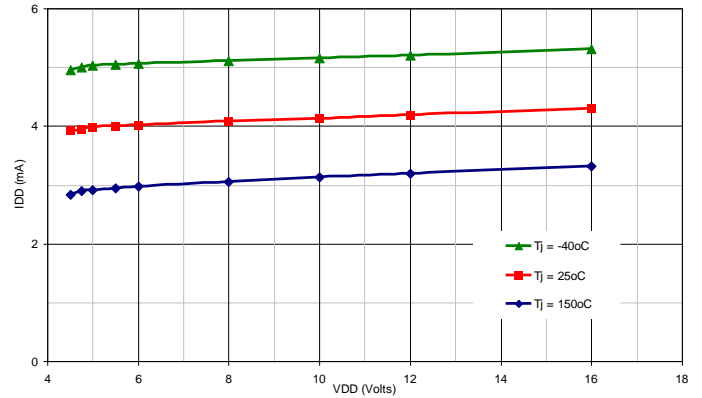

#### 8.3 $V_{OL}$ vs. $T_J$

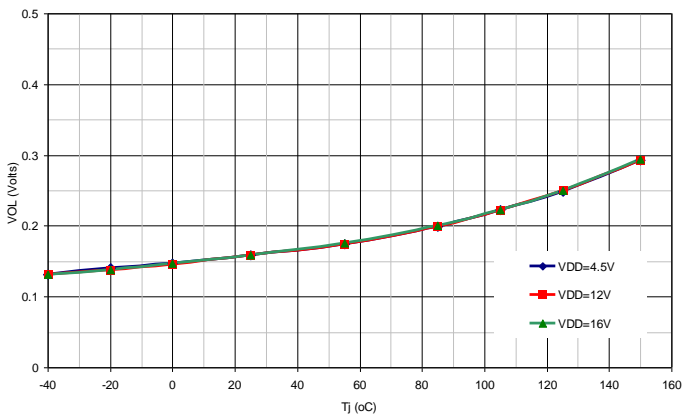

#### 8.4 $V_{OL}$ vs. $V_{DD}$

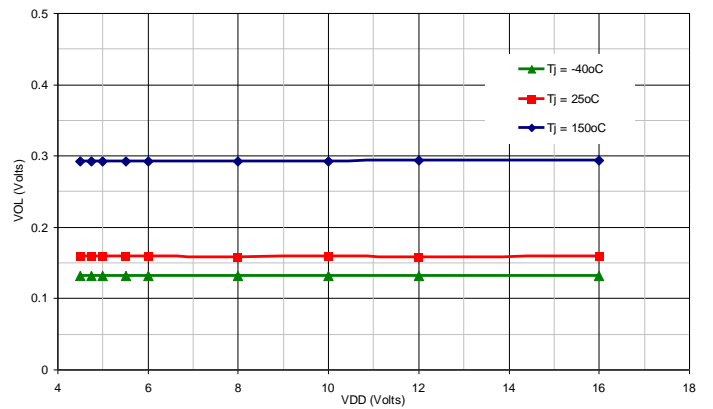

#### 8.5 $I_{OFF}$ vs. $T_J$

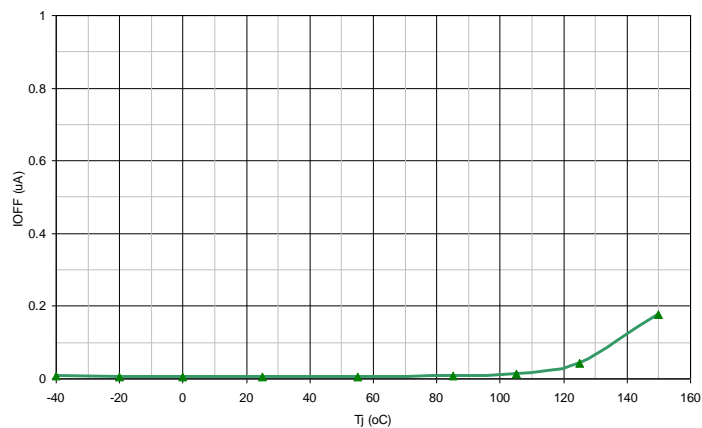

#### 8.6 Power Derating vs. $T_{amb}$

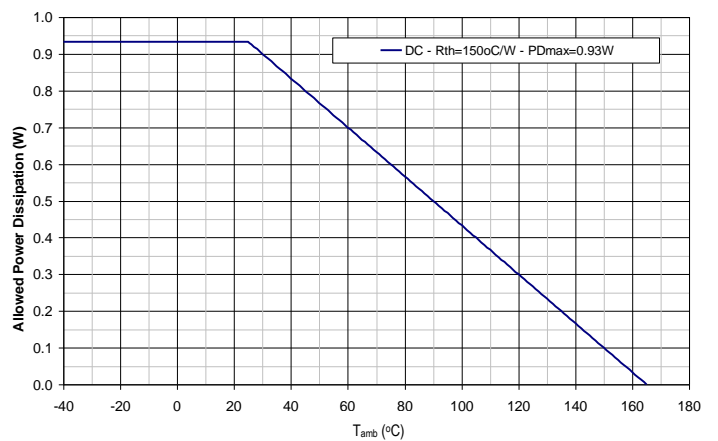

### 9 Application Information

#### 4-Wire PWM Cooling Fan

(no minimal speed setting)

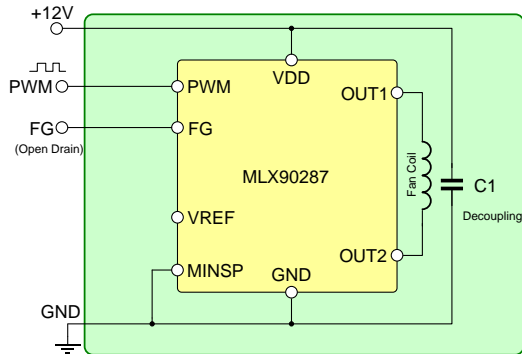

#### 4-Wire PWM Cooling Fan

(with minimal speed setting)

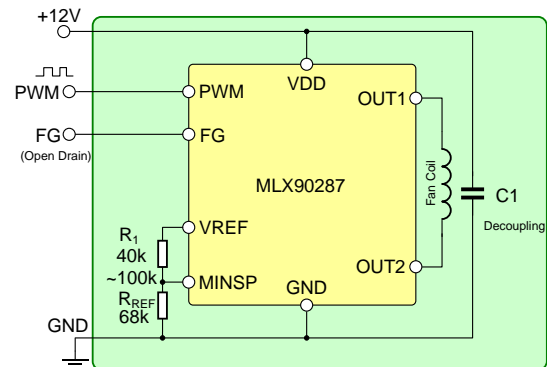

#### Temperature Controlled Cooling Fan

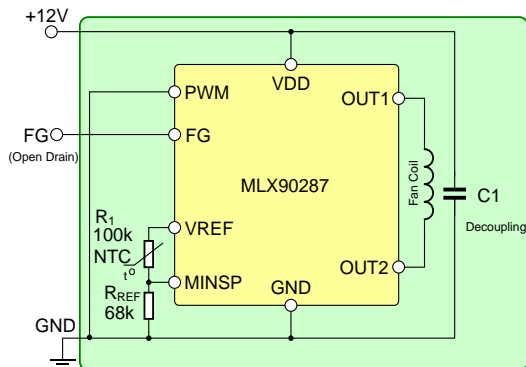

#### 2-Speed Cooling Fan

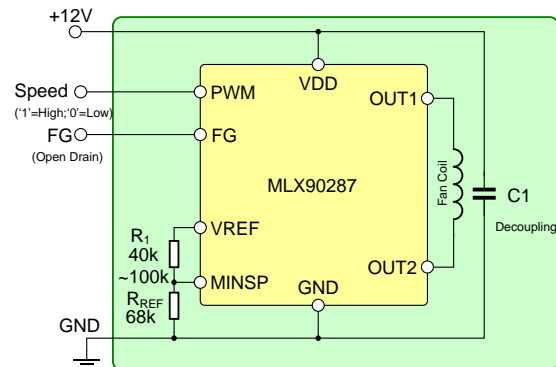

### 9.1 Application Comments

A decoupling capacitor from 100nF or higher should be placed as close as possible to the MLX90287 VDD and GND pins to increase the stability and protect against external noise and power surge.

Every application using the FG output pin requires a pull-up resistor either to the fan supply voltage (+12V), or to a separate voltage source.

### **10 Standard information regarding manufacturability of Melexis products with different soldering processes**

Our products are classified and qualified regarding soldering technology, solderability and moisture sensitivity level according to following test methods:

#### **Reflow Soldering SMD's (Surface Mount Devices)**

- IPC/JEDEC J-STD-020  
Moisture/Reflow Sensitivity Classification for Nonhermetic Solid State Surface Mount Devices (classification reflow profiles according to table 5-2)
- EIA/JEDEC JESD22-A113  
Preconditioning of Nonhermetic Surface Mount Devices Prior to Reliability Testing (reflow profiles according to table 2)

#### **Wave Soldering SMD's (Surface Mount Devices) and THD's (Through Hole Devices)**

- EN60749-20  
Resistance of plastic- encapsulated SMD's to combined effect of moisture and soldering heat
- EIA/JEDEC JESD22-B106 and EN60749-15  
Resistance to soldering temperature for through-hole mounted devices

#### **Iron Soldering THD's (Through Hole Devices)**

- EN60749-15  
Resistance to soldering temperature for through-hole mounted devices

#### **Solderability SMD's (Surface Mount Devices) and THD's (Through Hole Devices)**

- EIA/JEDEC JESD22-B102 and EN60749-21  
Solderability

For all soldering technologies deviating from above mentioned standard conditions (regarding peak temperature, temperature gradient, temperature profile etc) additional classification and qualification tests have to be agreed upon with Melexis.

The application of Wave Soldering for SMD's is allowed only after consulting Melexis regarding assurance of adhesive strength between device and board.

Melexis recommends reviewing on our web site the General Guidelines [soldering recommendation](http://www.melexis.com/Quality_soldering.aspx) ([http://www.melexis.com/Quality\\_soldering.aspx](http://www.melexis.com/Quality_soldering.aspx)) as well as [trim&form recommendations](http://www.melexis.com/Assets/Trim-and-form-recommendations-5565.aspx) (<http://www.melexis.com/Assets/Trim-and-form-recommendations-5565.aspx>).

Melexis is contributing to global environmental conservation by promoting **lead free** solutions. For more information on qualifications of **RoHS** compliant products (RoHS = European directive on the Restriction Of the use of certain Hazardous Substances) please visit the quality page on our website: <http://www.melexis.com/quality.aspx>

### **11 ESD Precautions**

Electronic semiconductor products are sensitive to Electro Static Discharge (ESD). Always observe Electro Static Discharge control procedures whenever handling semiconductor products.

---

# MLX90287

## 12V Low Noise Single Coil Motor Driver with PWM

### 12 Package Information

#### 12.1 DC Package (SOIC8 NB)

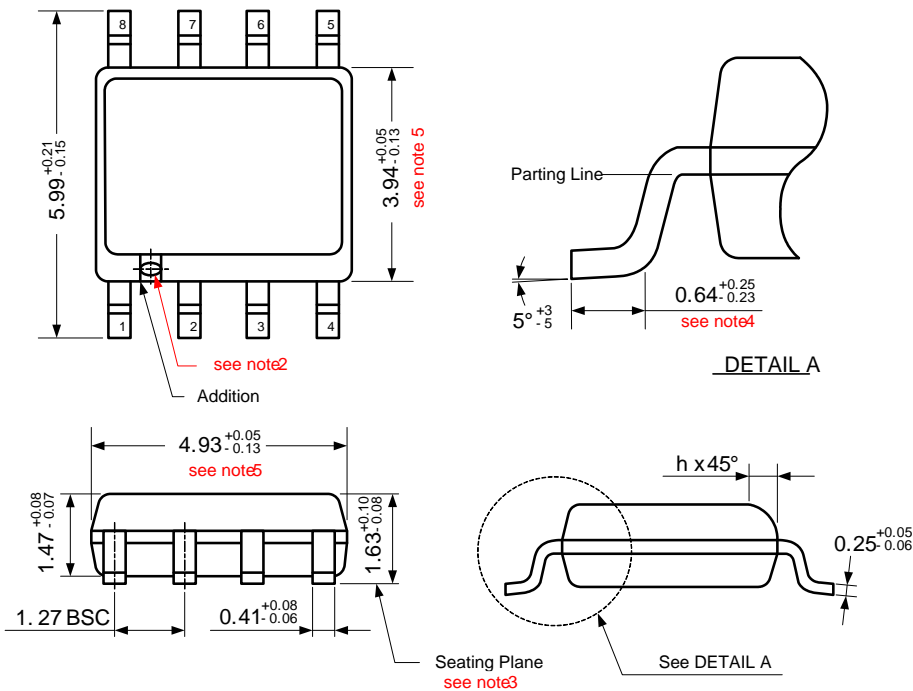

#### Notes:

1. Controlling dimensions in millimeters.
2. The appearance of pin 1 is optional, round type on single leadframe and rectangular type on matrix leadframe.
3. Formed leads shall be planar with respect to one another within 0.0792mm at seating plane.
4. Length of terminal for soldering to a substrate.
5. Package length and width are reference datums and do not include mold flash or protrusions, but does include mold mismatch and are measured at the mold parting line.  
Mold flash or protrusions shall not exceed 0.1524mm at end and 0.254mm at window.
6. This part is compliant with JEDEC standard MS-012.

Marking on top side is duplicated on bottom side

#### Hall plate location

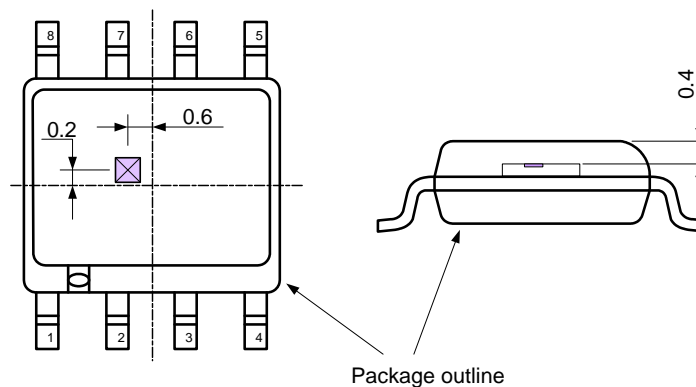

#### Marking DC package

Top side :	Bottom side : (identical to top side)
<i>Notch : marking of position of pin 1</i>	
Line 1 : 90287 : Name of device	Line 1 : 90287 : Name of device
Line 2 : FGyyww- (or RDyyyww) Date code	Line 2 : FGyyww- (or RDyyyww) Date code
FG : option code (90287-AAA)	FG : option code (90287-AAA)
RD : option code (90287-ABA)	RD : option code (90287-ABA)
yy : Year	yy : Year
ww : Calender week	ww : Calender week
Line 3 : Assembly lot (6 digits)	Line 3 : Assembly lot (6 digits)

# MLX90287

## 12V Low Noise Single Coil Motor Driver with PWM

### 12.2 ZC Package (SOIC8 NB with straight leads)

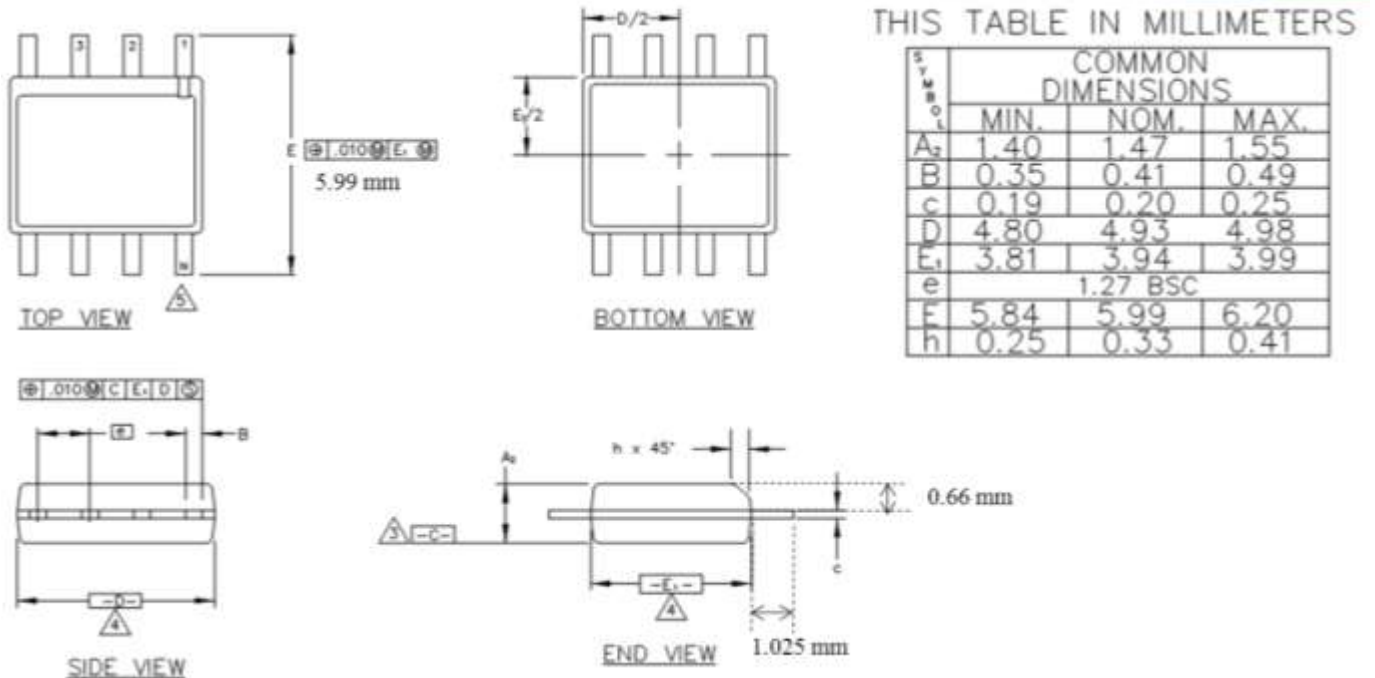

### Marking ZC package

Top side :	Bottom side :
<p><i>Notch : marking of position of pin 1</i></p> <p>No printed marking</p>	<p>Line 1 : 90287 : Name of device</p> <p>Line 2 : FGyyww- (or RDyyww) Date code</p> <p>FG : option code (90287-AAA)</p> <p>RD : option code (90287-ABA)</p> <p>yy : Year</p> <p>ww : Calender week</p> <p>Line 3 : Assembly lot (6 digits) + <b>white dot</b></p> <p><i>White dot : marking of position pin 1</i></p>

# MLX90287

## 12V Low Noise Single Coil Motor Driver with PWM

### 12.3 DFN10 3\*3mm

D x E	N	e		A	A1	A3	D2	E2	L	K	b
3 x 3	10	0.50	min	0.80	0.00	0.20	2.23	1.49	0.30	0.20	0.18
			max	1.00	0.05	REF	2.48	1.74	0.50	-	0.30

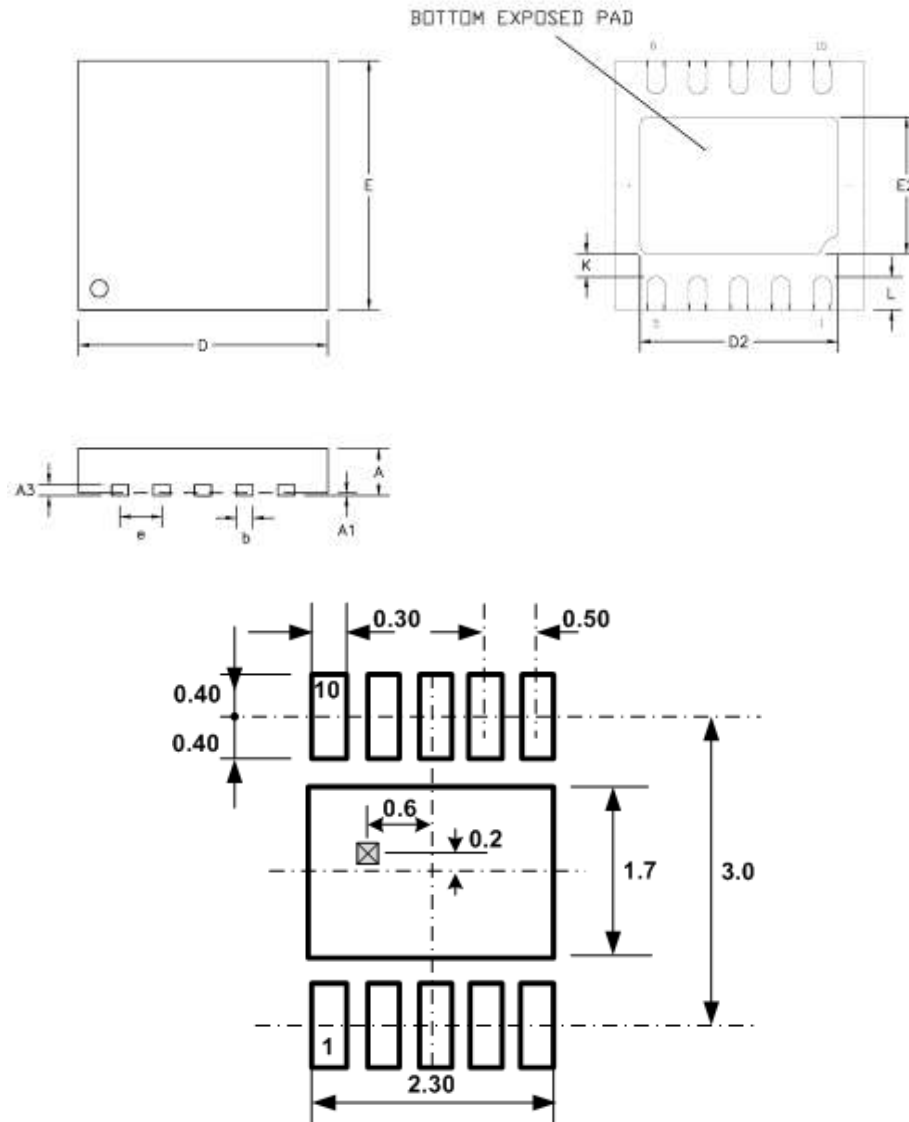

Layout Footprint and Hall plate location

Marking LD package (under review)

**Top side :**

*Notch : marking of position of pin 1*

Line 1 : 87xx : Name of device + assembly lot (2 digits)

Line 2 : xxxx : Assembly lot (4 digits)

Line 3 : yyww : Date code

yy : Year

ww : Calendar week

### **13 Disclaimer**

Devices sold by Melexis are covered by the warranty and patent indemnification provisions appearing in its Term of Sale. Melexis makes no warranty, express, statutory, implied, or by description regarding the information set forth herein or regarding the freedom of the described devices from patent infringement. Melexis reserves the right to change specifications and prices at any time and without notice. Therefore, prior to designing this product into a system, it is necessary to check with Melexis for current information. This product is intended for use in normal commercial applications. Applications requiring extended temperature range, unusual environmental requirements, or high reliability applications, such as military, medical life-support or life-sustaining equipment are specifically not recommended without additional processing by Melexis for each application.

The information furnished by Melexis is believed to be correct and accurate. However, Melexis shall not be liable to recipient or any third party for any damages, including but not limited to personal injury, property damage, loss of profits, loss of use, interrupt of business or indirect, special incidental or consequential damages, of any kind, in connection with or arising out of the furnishing, performance or use of the technical data herein. No obligation or liability to recipient or any third party shall arise or flow out of Melexis' rendering of technical or other services.

© Melexis NV. All rights reserved.

---